

	6	30	36.2	38	39.9	41	34.2	11.6g	21
	5	25	31.2	33	34.9	36	29.2	10.3g	18
	4	20	26.2	28	29.9	31	15.5	9.0g	15
	3	15	21.2	23	24.9	26	10.5	7.7g	12
	2	10	16.2	18	19.9	21	5.5	6.3g	9
	1	5	11.2	13	14.9	16	4.5	4.9g	6
M1:1	n	b	c ^{+0.1} _{-0.3}	d ^{+0.4} _{-0.3}	e ^{+0.2} _{-0.5}	f	g±0.25	WEIGHT Gewicht	NUMBER OF WAYS Polzahl

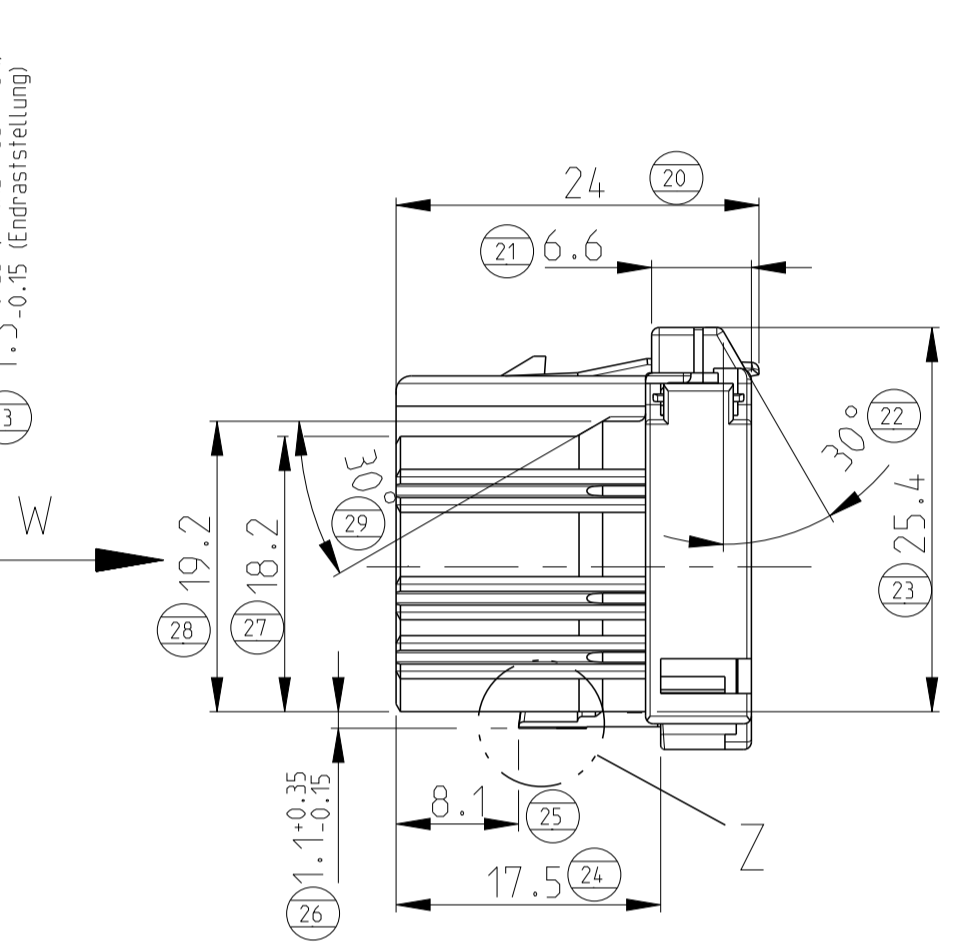

8-968974-1 AS SHOWN IN PRE-LOCKED POSITION wie gezeichnet in Vorraststellung

PRE-LOCKED AND FINAL POSITION
Vorrast- und Endraststellung

SLIDING DISTANCE: 1mm
Verschiebeweg: 1mm

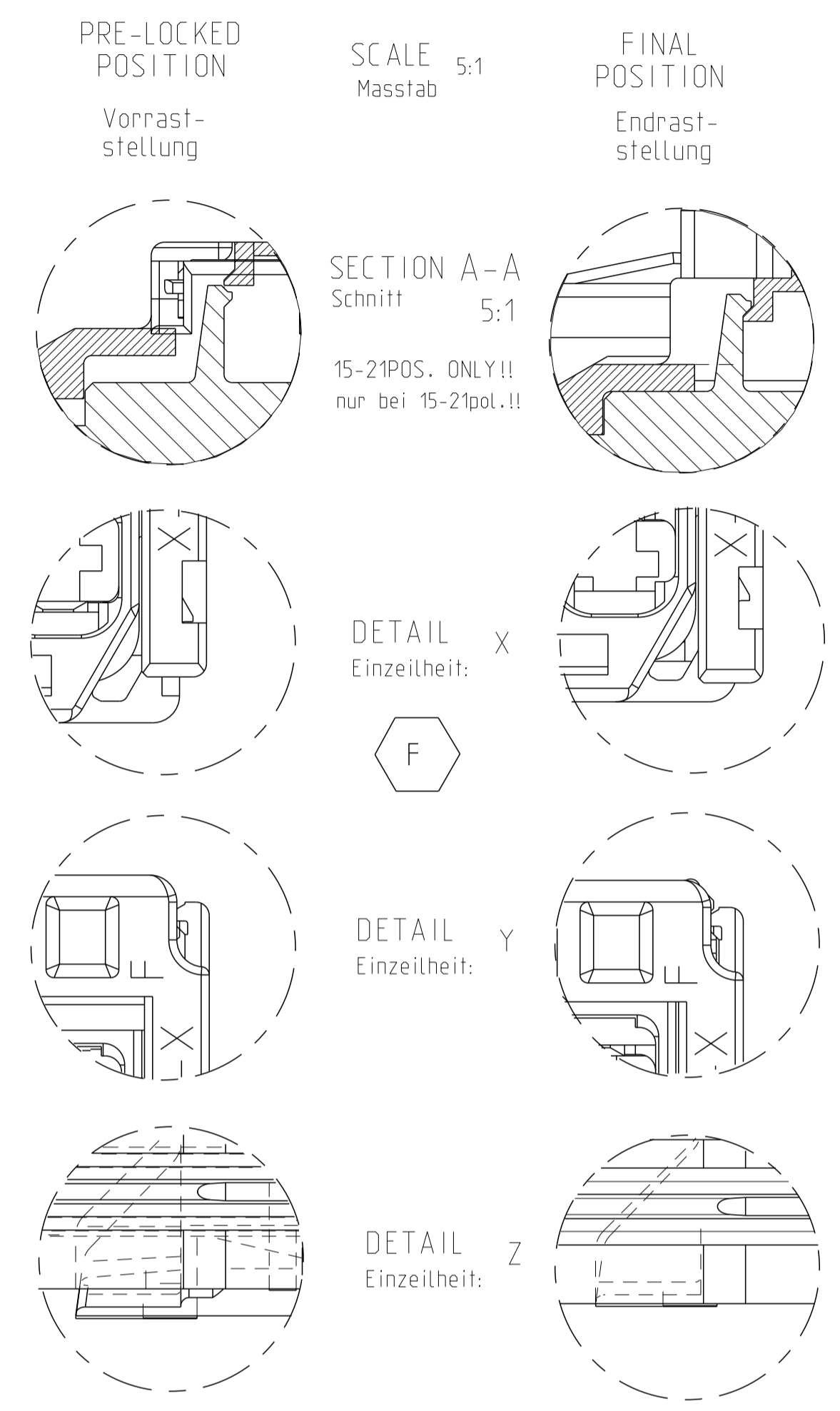

MATED WITH passend zu:		PROJEKT NR. A97-52046	LOC A1	DIST -	REVISIONS			
REV	DATE	DESCRIPTION	DATE	OWN	APVD			
E	29SEP2018	CHANGE OF BASE MATERIAL		HO.	SCHO			
E1	29NOV2018	PART REV. IN CHART ON SHEET 2 OF 2 REVISED		MAH.	SCHO			
E2	12FEB2019	SEE PCN E-19-002255		MAH.	SCHO			
F	21JAN2020	SEE PCN E-19-011087		MAH.	SCHO			

NOTES
Bemerkungen

- MATING CONNECTOR FOR AMP MCP 2.8 HOUSING
SEE DRAWINGS 1355072 (TAB HOUSINGS),
1964562 (TAB HOUSINGS),
966140 (TAB HEADER),
114-18085-025 (INTERFACE-DRAWING)
Gegenstecker fuer AMP MCP 2.8 Gehaeuse
siehe Zeichnungen 1355072 (Flachstecker-Gehaeuse),
1964562 (Flachstecker-Gehaeuse),
966140 (Messleiten),
114-18085-025 (Ausfuehrungsvorschrift)
- CAVITIES MATING WITH AMP MCP 2.8 CONTACTS
(WITHOUT SWS. MAX. WIRE SIZE: 2.5mm² FLR) -
SEE PRODUCT GROUP DRAWING: 1355036
Kontaktkammern passend fuer AMP MCP 2.8 Kontakte
(ohne EDS. max. Leitungsquerschnitt: 2.5mm² FLR)
- siehe Produktgruppenzeichnung : 1355036
- DESIGN DEPENDS ON NUMBER OF WAYS
Aussehen je nach Polzahl unterschiedlich
- WARPAGE TO ... PERMITTED
Verzug bis ... zulaessig
- MOULD CAVITY-MARKING = X
SERIAL MOULD-NUMBER = n. (if n>1 only)
Nestmarkierung = X
Serienwerkzeug-Nr. = n (nur wenn n>1)
- MATERIAL-MARKING ACC. TO VDA 260
Werkstoffkennzeichnung nach
- CAVITY-MARKING
Kammerbezeichnung
- THE REVISION STATUS OF THE MOULD
Aenderungszustand des Werkzeuges
- TE PARTNUMBER
TE Bestell-Nr. Teil
- WARPAGE TO 11.3 PERMITTED
Verzug bis 11.3 zulaessig
- PRODUCTION-DATE
Produktionsdatum
- PACKAGING: BULK PACKAGING IN CORRUGATED BOX -
INDICATED BY PRE-DASH-NO.s 8-, 7-, 6-, 5-;
THESE PRE-DASH-NO.s ARE ON PART NOW:
Verpackung: Schuetttgut in Versandkarton -
gekennzeichnet durch Vorstrichzahlen 8-, 7-, 6-, 5-;
diese Vorstrichzahlen sind jetzt auch am Teil!
- MALFUNCTION CAUSED BY LACQUER IS NOT
COVERED BY TE WARRANTY
Funktionbeeintraechtigung durch Lackieren liegt
nicht im Einfluss und Gewaehrleistungsumfang von TE
- COMPANY LOGO
Firmenzeichen

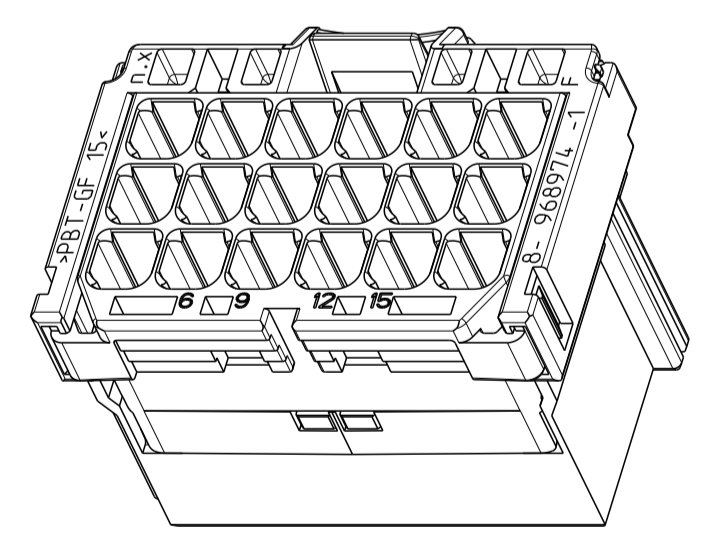

3D-MODEL (18POS.; CODING A)
2:1

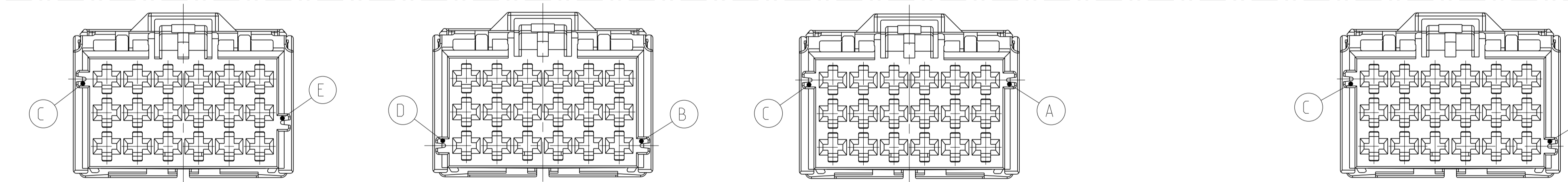

CODING / Kodierung D RIB / Rippe: C-E				CODING / Kodierung C RIB / Rippe: B-D				CODING / Kodierung B RIB / Rippe: A-C				CODING / Kodierung A RIB / Rippe: B-C				MECHAN. CODING mechann. Kodierung							
CUSTOMER PART NO. Kunden-Teile-Nr.	TE ORDER-NO TE Bestell-Nr.	REV	COLOUR Farbe	CUSTOMER PART NO. Kunden-Teile-Nr.	TE ORDER-NO TE Bestell-Nr.	REV	COLOUR Farbe	CUSTOMER PART NO. Kunden-Teile-Nr.	TE ORDER-NO TE Bestell-Nr.	REV	COLOUR Farbe	CUSTOMER PART NO. Kunden-Teile-Nr.	TE ORDER-NO TE Bestell-Nr.	REV	COLOUR Farbe	CUSTOMER PART NO. Kunden-Teile-Nr.	TE ORDER-NO TE Bestell-Nr.	REV	COLOUR Farbe	POS.	DESCRIPTION Benennung Einzelteil	MATERIAL Werkstoff	
			CLARET VIOLET Bordeauxviolett				LIGHT BLUE Lichtblau				NATURE natur												

THIS DRAWING IS A CONTROLLED DOCUMENT.

APVD: M. Bleicher 18JAN2008

TE Connectivity

PRODUCT GROUP DRAWING FOR: AMP MCP 2.8 HSG.
6-21POS. WITH SECONDARY LOCKING DEVICE
Produkt-Gruppen-Zeichnung fuer: AMP MCP 2.8 Gehaeuse.
6-21polig mit zweiter Kontaktsicherung

SIZE: 108-18619-3
DRAWING NO: 114-94624
WEIGHT: SEE TABLE
SCALE: 2:1